

TWIN PLATE CHECK VALVES

GENERAL CATALOGUE

ABACUS VALVES INTERNATIONAL LTD

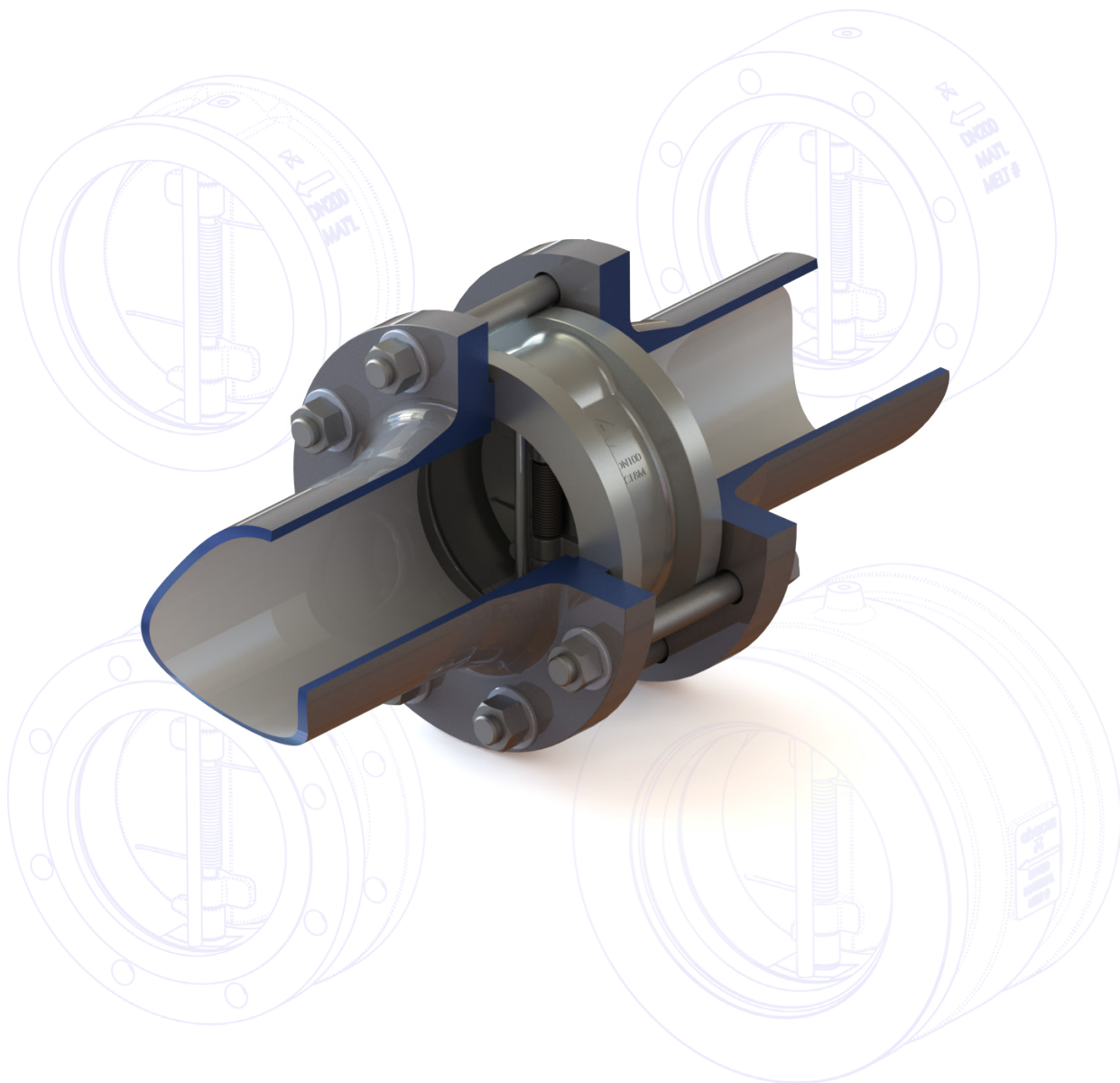

www.abacusvalves.com



UK check valve specialists since 1988



ABACUS VALVES INTERNATIONAL LTD

Abacus Valves is an international supplier of check (non return) valves with over 25 years of market history for the design, manufacture and supply of its approved products.



Utilising global alliance partners, Abacus has successfully served a wide range of industries including energy, oil and gas, petrochemical, nuclear, pharmaceutical, marine, mining, and water. Project references are available on request and diversification into new sectors welcomed.

The engineering pedigree within the group ensures that Abacus can cater for a wide range of solutions whether it be materials of manufacture or specialist design and simulation analysis. Using a combination of conventional machining and hi-tech CNC methods in direct correlation with the latest 3D CAE software, products are produced and inspected to the highest degree.

Abacus core competencies include: design, manufacture, assembly, inspection, test and overhaul.

With a focus on quality supply for both commodity and project based orders, Abacus typically carries over £1M worth of stock goods ranging from standard twin plates to wafer swing types to high performance axial non slam nozzle check valves.

Further investment of in-house test facilities has allowed Abacus to strengthen its ability to offer a comprehensive package to the industries it serves.

Quality/Accreditations

ISO 9001:2008
 PED 2014/68/EU
 CU-TR 010 & 032
 Achilles JQS & FPaI

Sales

Commercial and technical assistance is available through our internal and external sales teams. With vast experience in the valve industry, on-site technical assistance can be provided when required.

ABACUS AT A GLANCE

- 1988 Founded in Alton Hampshire, England UK
- 2003 Relocate to Kilbirnie, Scotland, UK.

Product Range

- Twin Plate Check Valves
- Non-Slam Axial Nozzle Check Valves
- Axial Sprung Disc Check Valves
- Wafer Single Plate Swing Check Valves

Quality

- ISO 9001:2008
- PED 2014/68/EU
- CU-TR 010 & 032
- Achilles JQS & FPaI
- ASME IX qualified in-house welding
- ANST Level II qualified DPI & MPI
- In-house PMI (portable XRF analyzer)

Stock

- Norsok / Statoil qualified range
- Economy UK C.O.O. range
- Part machined castings available for quick turnaround as finished valves

CONTENTS

ABACUS PROFILE	2
CHECK VALVES - A GENERAL OVERVIEW	4
ABACUS TWIN PLATE CHECK VALVES	5
TWIN PLATE OPERATIONAL OVERVIEW	6
DESIGN FEATURES	7
STANDARD PART No. CONFIGURATOR	8-9
WAFER CHECK VALVE READY RECKONER	10
STANDARD TWIN PLATE RANGE	11
4X7 RANGE (Wafer Style)	12-14
4X7L RANGE (Solid Lugged Style)	15-17
4X7U (Double Flanged Style)	18-19
4X4 (Double Flanged Extended Body Style)	20-21
4X7H (Hub Ended Style)	22
SPECIALS	23-24
STANDARD CONFIGURATIONS	25
PRESSURE DROP CHART	26
OTHER PRODUCTS	27
CERTIFICATION & APPROVALS	28
VALVE DATA SHEET - QUESTIONNAIRE	29

CHECK VALVES

Check valves, or non-return valves, are installed in pipeline systems to permit fluid flow in one direction only and close automatically and instantaneously if flow is interrupted or reversed.

They depend on line pressure and velocity to open and close.

The basic principle in all check valves is common:

- An obturator (e.g. disc, plate) moves into its open position under conditions of normal flow. When flow is stopped, or reversed, the obturator closes the valve
- Some valve designs incorporate springs or external weighted levers to provide additional forces and make the valve self-acting
- Gravity and back pressure are other examples of forces which can be combined to aid closure of the valve

Correct Sizing:

- Line velocity pressure must be capable of holding the obturator in a stable, fully open position. Insufficient line velocity pressure can result in premature wear, turbulence, vibration and noisy operation

Typical applications of check valves:

- Protection of any item of equipment that can be affected by reverse flow (i.e. pumps, control valves, flow-meters etc)
- Prevention of reverse flow on system shutdown
- Prevention of flooding
- Prevention of flow under gravity
- Relief of vacuum conditions

Note:

Although check valves can effectively shut off reverse flow, they should never be used in place of an isolation valve.

ABACUS TWIN PLATE CHECK VALVES

The Abacus twin plate check valve provides an economical, efficient and dynamically responsive alternative to traditional check valves like the full bodied swing type. The twin plate can be installed horizontally, vertically (flow up) or customised for vertically (flow down).

This compact, spring assisted, valve option is installed sandwiched between any recognised flange arrangement with the stop pin vertically positioned.

The valve geometry takes the form of a simple cylinder with a vertical central web. This slim cylindrical profile offers a high strength, high flow capacity, self acting check valve solution.

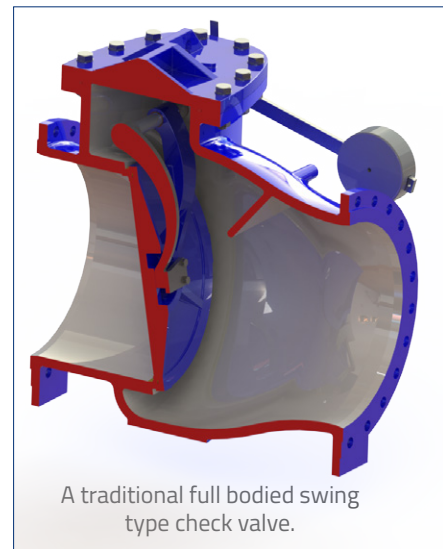
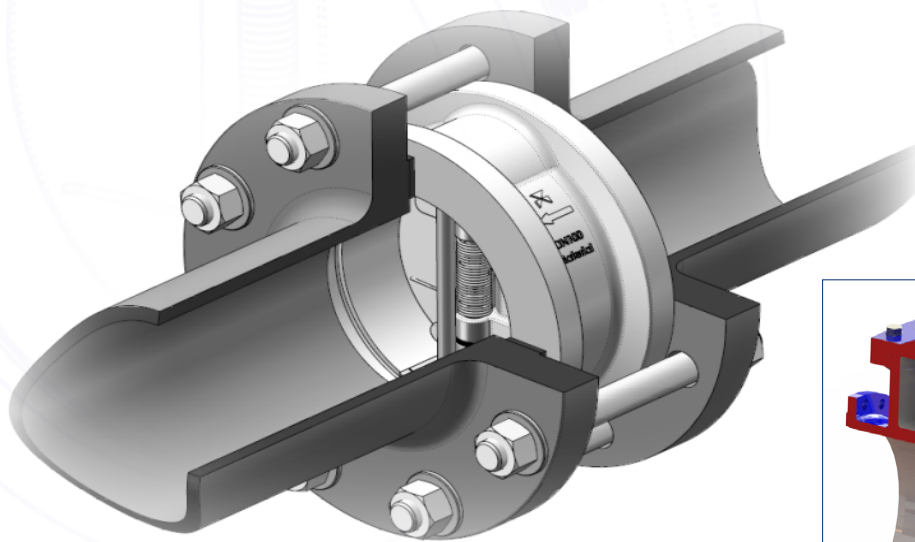

A traditional full bodied swing type check valve.

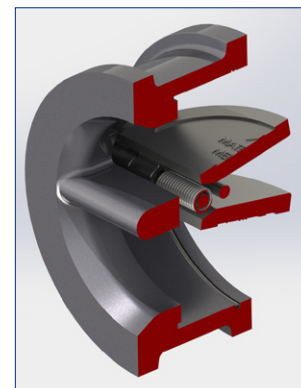

The Abacus Twin Plate check valve (rotated 90°).

For maximum service life the twin plate check valve should ideally be installed:

A minimum of 5 pipe diameters downstream of any piping component (e.g. pump, compressor, control valve, elbow etc.), with a minimum distance of 2 pipe diameters upstream of any tee's, elbows or other relevant piping equipment maintained.

Twin plate check valves are NOT pigable.

TWIN PLATE OPERATIONAL OVERVIEW

VALVE FULLY OPEN

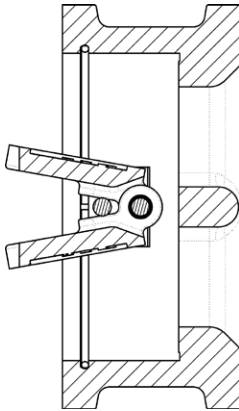

VALVE OPENING

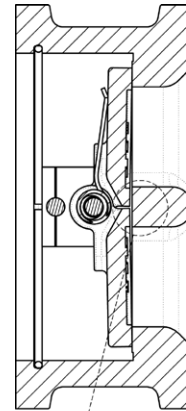
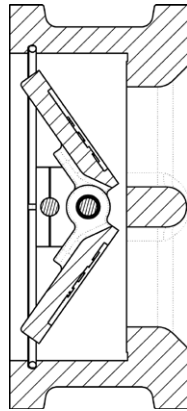

VALVE CLOSED

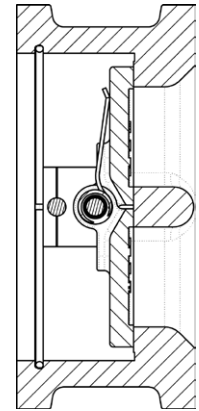

DIRECTION OF FLOW

The Abacus Twin Plate Check Valve works on the following principle:

- Two sprung loaded, semi-circular plates hinged on a vertical pin
- The torsion spring contact legs are designed such that the resultant spring force acts beyond the centroid of the plate(s). The plates are designed for a clearance fit between the hinge bores and the vertical hinge pin
- When the upstream (inlet) fluid force is greater than the spring force, the plates move off the seat, heel first as the resultant force acts at the plate centroid position and flow is induced. This prevents the plates from scuffing the seat
- As flow rate increases the plates rotate towards a fully open position where they stop against the top pin
- When the flow starts to decelerate, the plates react immediately with the aid of the spring, to move back towards the seat
- The plates will fully close against the seat just before backflow starts, forming a non-slam, tight shut-off

TWIN PLATE CHECK VALVES

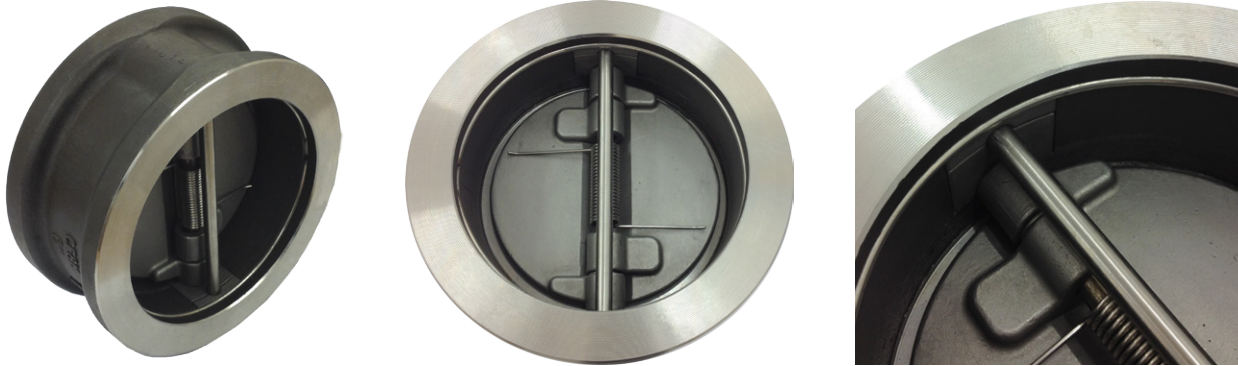

- Fully API 598 compliant.
- ASME B16.34 P/T Ratings.
- PED 2014/68/EU (Formerly 97/23/EC).
- Continuous, uninterrupted flange faces.
- Resilient seat options (integral and renewable).
- Precision lapped metal seat option (inherently fire safe).
- Retainerless design as standard (no leak path to atmosphere).
- No external actuation aids required.



- Optional *Thru-flo* design on high pressure plates.
- Can be tailored to suit bespoke requirements.
- Increased flow capacity and strength to weight ratio.
- Retrofit's into existing design.

- Stand-off bush for independent plate hinging.
- Lowers axial hinge friction co-efficient of plates.
- Common on large diameter valves.
- Aids simultaneous closure of plates.
- Wide range of bush materials available.

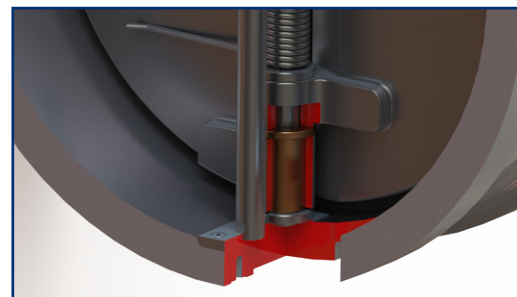

STANDARD PART NUMBER CONFIGURATOR

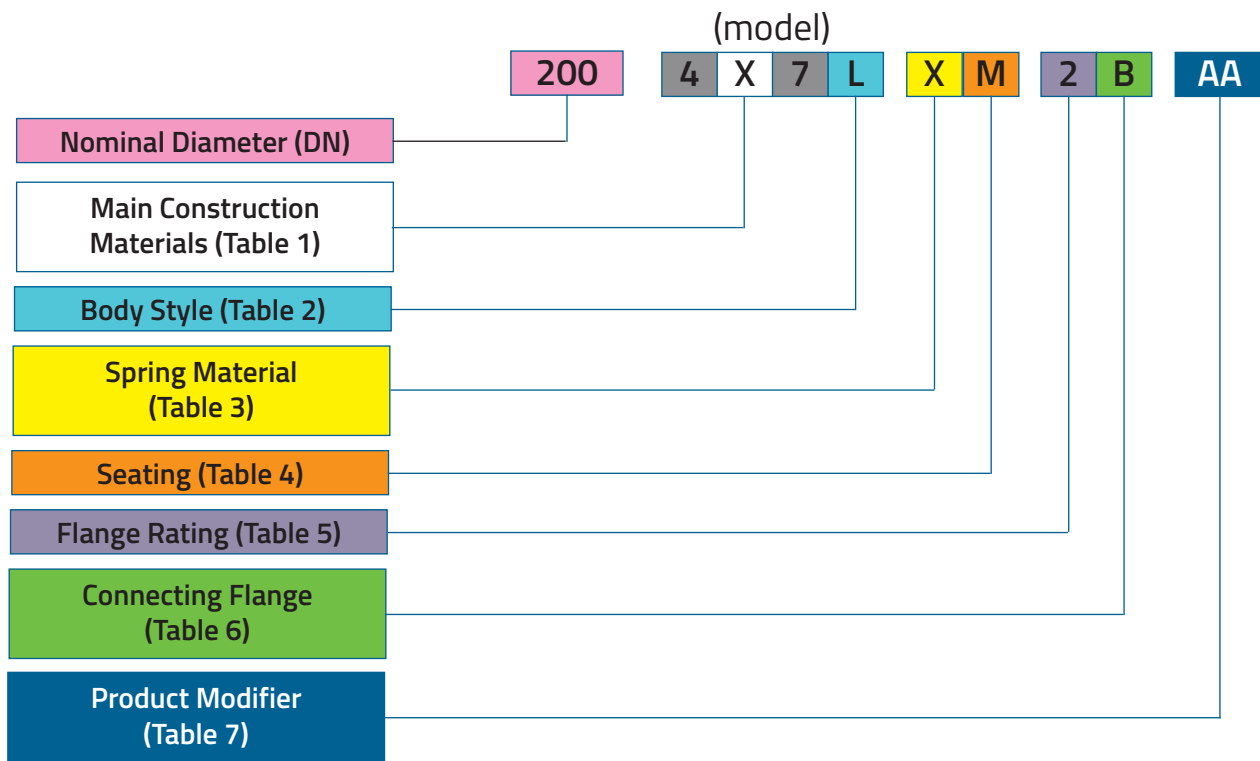

Table 1

Code	Main Construction Material	Code	Main Construction Material
0	Gunmetal (CC491K / LG2)	21	L.T. Forged Carbon Steel (ASTM A350 LF2)
1	Ni Al Bronze (ASTM B148 C95800 / EN12163 CW307G)	22	Leaded Red Brass (ASTM B62 C83600)
2	Carbon Steel (ASTM A216 WCB / ASTM A105)	23	Ductile Iron (EN-GJS-450-10)
3	L.T. Carbon Steel (ASTM A352 LCC)	24	Ductile Iron (EN-GJS-500-7)
4	Aust. St. Steel (ASTM A351 CF8M / ASTM A182 F316)	25	Ni Alloy (UNS N08825 / Incoloy®825)
5	Ni Cu Alloy (ASTM A494 M35-1 / UNS N04400 / Monel® 400)	26	Carbon Steel (070M20)
6	Titanium (ASTM B367 C2 / ASTM B348 Gr 2 / ASTM B381 F2)	27	Sup. Aust. St. Steel (ASTM A351 CK3MCuN / ASTM A182 F44)
7	Ni Alloy (ASTM A494 CW12MW / UNS N10276 / Hastelloy® C276)	28	Ni Alloy (UNS N07718 / Inconel® 718)
8	Duplex SS (ASTM A995 Gr 4A / ASTM A182 F51)	29	Mart. St. Steel (ASTM A217 CA15 / ASTM A182 F6)
9	Grey Cast Iron (EN-GJL-250)	30	Aust. St. Steel (ASTM A351 CF3 / ASTM A182 F304L)
10	Super Duplex SS (ASTM A995 Gr 5A / ASTM A182 F53)	31	Aust. St. Steel (UNS N08904 / 904L)
11	Super Duplex SS (ASTM A995 Gr 6A / ASTM A182 F55)	32	Aluminium Alloy (BS EN573 6082-T6)
12	Aust. St. Steel (ASTM A351 CF8 / ASTM A182 F304)	33	Carbon Steel (ASTM A216 WCC)
13	Aust. St. Steel (ASTM A351 CF3M / ASTM A182 F316L)	34	Titanium (ASTM B367 C5 / ASTM B348 Gr 5 / ASTM B381 F5)
14	Ni Alloy (ASTM A494 CW6MC / UNS N06625 / Inconel®625)	35	Co-Cr Alloy (Stellite®6)
15	Mart. St. Steel (ASTM A487 CA6NM / UNS S42400)	36	Mart. St. Steel (ASTM A182 F6NM)
16	L.T. Carbon Steel (ASTM A352 LCB)	37	Aust. St. Steel (ASTM A351 CF8C / ASTM A182 F347-H)
17	Aust. St. Steel (ASTM A351 CK20 / ASTM A182 F310)	38	Ductile Iron (EN-GJS-400-15)
18	Ni Alloy (ASTM A351 CN7M / UNS N08020 / Alloy 20)	39	Aust. St. Steel (ASTM A182 F321-H)
19	Ni Alloy (UNS N02200 / Alloy 200)	40	Ni Cu Alloy (ASTM A494 M30C)
20	Aust. St. Steel (ASTM A351 CG3M)	41	Duplex SS (ASTM A995 Gr 1B)

Table 2

Code	Body Style
(blank)	Default Wafer (non-lugged)
L	Solid Lugged, Through Drilled
U	Double Flanged (not applicable to 4X4 Range)
T	Tapped Lugged

STANDARD PART NUMBER CONFIGURATOR

Table 3

Code	Spring Material
X	UNS N07750 (Inconel® X-750)
Y	UNS N07718 (Inconel® 718)
I	UNS N06625 (Inconel® 625)
H	UNS N10276 (Hastelloy® C-276)
S	AISI 316 St. Steel
M	Monel® K500
E	Elgiloy®

Table 5

Code	Flange Rating
1	ASME Class 125
2	ASME Class 150
4	ASME Class 300
5	ASME Class 600
6	ASME Class 900
7	ASME Class 1500
8	ASME Class 2500
06	PN6
10	PN10
16	PN16
25	PN25
40	PN40
63	PN63
100	PN100
D	BS 10 Table D
E	BS 10 Table E
F	BS Table F
J5	JIS B2220 5K
J10	JIS B2220 10K
J16	JIS B2220 16K
J20	JIS B2220 20K
J30	JIS B2220 30K
20	API 6A 2000 PSI
30	API 6A 3000 PSI
50	API 6A 5000 PSI
100BX	API 6A 10000 PSI

Table 6

Code	Connecting Flange
A	Flat Faced (FF)
B	Raised Face (RF)
C	Ring Type Joint (RTJ)
H	Hub End

Table 4

Code	Seating
M	Metal-Metal
V	Resilient (Viton®)
B	Nitrile (NBR, Buna-N)
P	P.T.F.E.
H	Stellite®6 Weld Overlay (Hardfaced)
I	Inconel®625 Weld Overlay
O	316 SS Weld Overlay
C	13% Cr Weld Overlay
E	Resilient (EPDM)
Q	Monel®400 Weld Overlay
N	Resilient (Neoprene)
D	F51 Duplex Weld Overlay
T	Ultimet® / Triballoy®800 Weld Overlay (Hardfaced)
K	PEEK

Table 7

Code	Product Modifier
AA	CA6NM / S42400 Internals
AB	Ni Al Bronze (C95800 / CW307G) Internals
AC	Ni Alloy (M35-1 / M30C / UNS04400) Internals
AD	Aust. St. Steel (CF3M / F316L) Internals
AE	Aust. St. Steel (CF8 / F304) Internals
AF	Duplex (Gr 4A / F51) Internals
AG	Mart. St. Steel (CA15 / F6 / AISI 410) Internals
AH	Duplex (Gr 4A / F51) Disc/Plates
AI	Super Duplex (Gr 6A / F55) Internals
AJ	Aust. St. Steel (CF8M / F316 / AISI 316) Disc/Plates
AK	Co-Cr Alloy (Stellite®6) Plates
AL	Ni Alloy (CW6MC / UNS N06625) Internals
AM	Ni Alloy (UNS N06625) Guide Bushing
AN	Mart. St. Steel (F6NM) Internals
AO	Titanium (C5 / Gr 5) Disc/Plates
AP	Renewable Resilient Seat
AQ	P.T.F.E. (25% G.R.) Disc/Plates
AR	Ni Al Bronze (CW307G/CA104) Guide Bushing

FOR ALTERNATIVE MATERIALS, FLANGE STANDARDS AND SPRING CONFIGURATIONS PLEASE CONSULT ABACUS VALVES.

WAFER CHECK VALVE READY RECKONER

Nominal Wafer Outer Diameters (mm)

SIZE		PRESSURE RATING												
DN	NPS	PN6	PN10	PN16	PN25	PN40	Tab D	Tab E	CL150	CL300	CL600	CL900	CL1500	CL2500
50	2	98	109	109	109	109	99	99	105	111	111	143	143	146
65	2½	118	129	129	129	129	111	111	124	130	130	165	165	168
80	3	134	144	144	144	144	130	130	137	149	149	168	174	197
100	4	154	164	164	170	170	162	162	175	181	193	206	209	235
125	5	184	194	194	196	196	194	194	197	216	241	247	254	279
150	6	209	220	220	226	226	219	216	222	251	266	289	282	317
200	8	264	275	275	286	293	276	273	279	308	320	359	352	387
250	10	319	330	331	343	355	336	336	339	362	400	435	435	476
300	12	375	380	386	403	420	387	384	409	422	457	498	520	549
350	14	425	440	446	460	477	448	448	451	486	492	521	578	-
400	16	475	491	498	517	549	499	499	514	540	565	575	641	-
450	18	-	541	558	567	574	562	562	549	597	613	638	705	-
500	20	580	596	620	627	631	619	619	606	654	683	699	756	-
600	24	681	698	737	734	747	730	730	718	775	791	838	902	-

Nominal Wafer Face to Face (mm)

SIZE		PRESSURE RATING												
DN	NPS	PN6	PN10	PN16	PN25	PN40	Tab D	Tab E	CL150	CL300	CL600	CL900	CL1500	CL2500
50	2	60	60	60	60	60	60	60	60	60	60	70	70	70
65	2½	67	67	67	67	67	67	67	67	67	67	83	83	83
80	3	73	73	73	73	73	73	73	73	73	73	83	83	86
100	4	73	73	73	73	73	73	73	73	73	79	102	102	105
125	5	-	-	-	-	-	-	-	-	-	-	-	-	-
150	6	98	98	98	98	98	98	98	98	98	136	159	159	159
200	8	127	127	127	127	127	127	127	127	127	165	206	206	206
250	10	146	146	146	146	146	146	146	146	146	213	241	248	254
300	12	181	181	181	181	181	181	181	181	181	229	292	305	305
350	14	184	184	184	222	222	184	184	184	222	273	356	356	-
400	16	191	191	191	232	232	191	191	191	232	305	384	384	-
450	18	203	203	203	264	264	203	203	203	264	362	451	468	-
500	20	219	219	219	292	292	219	219	219	292	368	451	533	-
600	24	222	222	222	218	318	222	222	222	318	438	495	559	-

Notes:

Face to Face dimension's shown are in compliance with API594.
 Values shown are nominal and subject to ASME B16.10 tolerances:

- ±2mm for valves DN250 (10") and smaller.
- ±3mm for valves DN300 (12") and larger.

FOR ALTERNATIVE SIZES, PRESSURE RATINGS & FLANGE STANDARDS PLEASE CONSULT ABACUS VALVES.

STANDARD TWIN PLATE RANGE



4X7 Range

Wafer Design
API 594 Compliant
CL150-2500
DN50-600

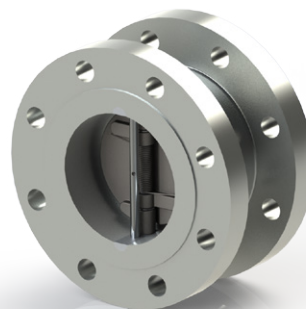

4X4 Range

Double Flanged
Extended Body Design
CL150-600
DN50-250

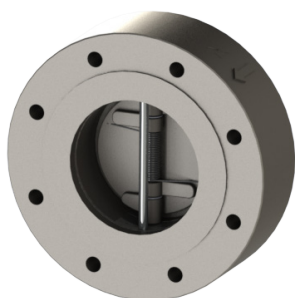

4X7L Range

Solid Lugged Design
API 594 Compliant
CL150-2500
DN50-600



4X7H Range

Hub Ended Design
CL900-2500
DN50-600

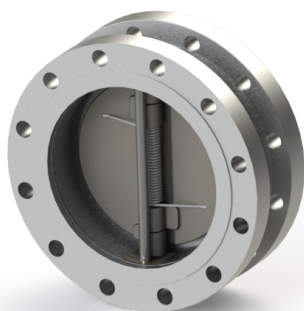

4X7U Range

Double Flanged Design
API 594 Compliant
CL150-2500
DN200-600

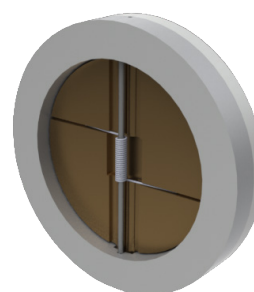

Specials

Compact Wafer Design
CL150-300
DN50-300

4X7 RANGE

- Wafer type
- Retainerless design as standard (no leak path to atmosphere)
- Metal to metal seating for inherent fire safety
- Resilient seat option
- API 594 Design Standard
- ASME B16.34 Pressure/Temperature ratings
- PED 2014/68/EU (Cat III and below)

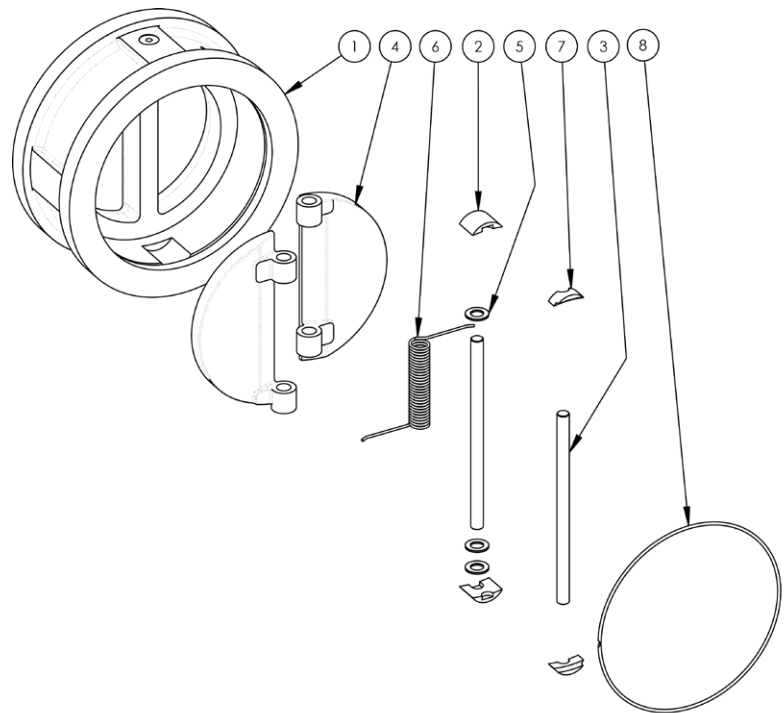

Item No.	Description	Qty
1	BODY	1
2	PIN CARRIER (BTM)	2
3	PIN	2
4	PLATE (DISC)	2
5	BEARING	-
6	TORSION SPRING	1
7	PIN CARRIER (TOP)	2
8	RETAINING CLIP	1

VIEW SHOWN IS GENERIC REPRESENTATION ONLY

4X7 PRINCIPAL DIMENSIONS

ASME B16.5

DN	NPS	ASME Rating	End Facing	ØA (mm)	B (mm)	ØC (mm)	Approx Mass (kg)
50	2"	150	RF	105	60	60	3
		300	RF	111	60	60	3
		600	RF/RTJ 23	111	60	60	3
		900	RF/RTJ 24	143	70	60	6
		1500	RF/RTJ 24	143	70	60	6
		2500	RF/RTJ 26	146	70	60	7
65	2.5"	150	RF	124	67	73	4
		300	RF	130	67	73	5
		600	RF/RTJ 26	130	67	73	5
		900	RF/RTJ 27	165	83	73	7
		1500	RF/RTJ 27	165	83	73	7
		2500	RF/RTJ 28	168	83	73	7
80	3"	150	RF	137	73	89	5
		300	RF	149	73	89	7
		600	RF/RTJ 31	149	73	89	7
		900	RF/RTJ 31	168	83	89	11
		1500	RF/RTJ 35	174	83	89	11
		2500	RF/RTJ 32	197	86	89	15
100	4"	150	RF	175	73	114	7
		300	RF	181	73	114	8
		600	RF/RTJ 37	193	79	114	12
		900	RF/RTJ 37	206	102	114	18
		1500	RF/RTJ 39	209	102	114	20
		2500	RF/RTJ 38	235	105	114	25

DN	NPS	ASME Rating	End Facing	ØA (mm)	B (mm)	ØC (mm)	Approx Mass (kg)
125	5"	150	RF	197	86	141	14
		300	RF	216	86	141	16
		600	RF/RTJ 41	241	TBC	141	TBC
		900	RF/RTJ 41	247	TBC	141	TBC
		1500	RF/RTJ 44	254	TBC	141	TBC
		2500	RF/RTJ 42	279	TBC	141	TBC
150	6"	150	RF	222	98	170	15
		300	RF	251	98	170	20
		600	RF/RTJ 45	266	136	170	36
		900	RF/RTJ 45	289	159	170	52
		1500	RF/RTJ 46	282	159	170	50
		2500	RF/RTJ 47	317	159	170	85
200	8"	150	RF	279	127	220	30
		300	RF	308	127	220	37
		600	RF/RTJ 49	320	165	220	61
		900	RF/RTJ 49	359	206	220	104
		1500	RF/RTJ 50	352	206	220	100
		2500	RF/RTJ 51	387	206	220	130
250	10"	150	RF	339	146	275	50
		300	RF	362	146	275	57
		600	RF/RTJ 53	400	213	275	108
		900	RF/RTJ 53	435	241	275	175
		1500	RF/RTJ 54	435	248	275	180
		2500	RF/RTJ 55	476	254	275	230

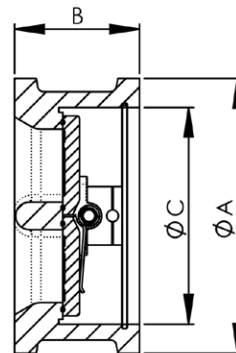
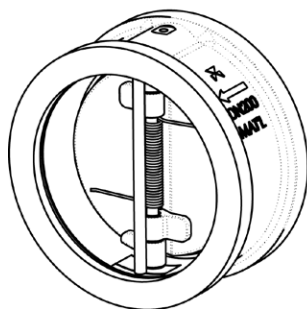

Notes:

Dimension's shown are nominal values only.

Weights may vary depending on manufacturing technique and corrosion allowance requirements.

4X7 PRINCIPAL DIMENSIONS

ASME B16.5

DN	NPS	ASME Rating	End Facing	ØA (mm)	B (mm)	ØC (mm)	Approx Mass (kg)
300	12"	150	RF	409	181	321	85
		300	RF	422	181	321	91
		600	RF/RTJ 57	457	229	326	151
		900	RF/RTJ 57	498	292	326	245
		1500	RF/RTJ 58	520	305	326	330
		2500	RF/RTJ 60	549	305	326	440
350	14"	150	RF	451	184	360	100
		300	RF	486	222	360	147
		600	RF/RTJ 61	492	273	356	206
		900	RF/RTJ 62	521	356	356	420
		1500	RF/RTJ 63	578	356	356	430
		2500	-	-	-	-	-
400	16"	150	RF	514	191	406	165
		300	RF	540	232	406	188
		600	RF/RTJ 65	565	305	406	290
		900	RF/RTJ 66	575	384	390	525
		1500	RF/RTJ 67	641	384	390	630
		2500	-	-	-	-	-

DN	NPS	ASME Rating	End Facing	ØA (mm)	B (mm)	ØC (mm)	Approx Mass (kg)
450	18"	150	RF	549	203	458	185
		300	RF	597	264	458	252
		600	RF/RTJ 69	613	362	458	404
		900	RF/RTJ 70	638	451	458	600
		1500	RF/RTJ 71	705	468	458	860
		2500	-	-	-	-	-
500	20"	150	RF	606	219	508	250
		300	RF	654	292	508	329
		600	RF/RTJ 73	683	368	508	508
		900	RF/RTJ 74	699	451	500	650
		1500	RF/RTJ 75	756	533	500	1250
		2500	-	-	-	-	-
600	24"	150	RF	718	222	610	300
		300	RF	775	318	610	450
		600	RF/RTJ 77	791	438	610	925
		900	RF/RTJ 78	838	495	600	1250
		1500	RF/RTJ 79	902	559	600	2000
		2500	-	-	-	-	-

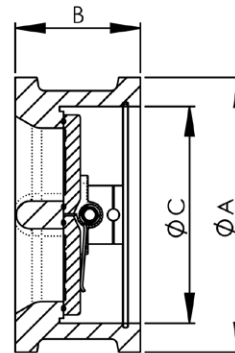
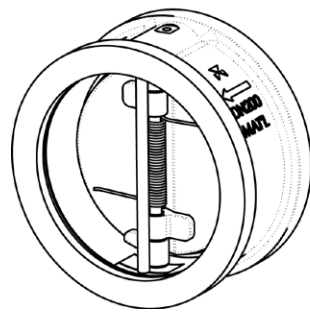

FOR ALTERNATIVE PRESSURE RATINGS, FLANGE STANDARDS AND LARGER SIZES CONSULT ABACUS VALVES INTERNATIONAL LTD.

Notes:

Dimension's shown are nominal values only.

Weights may vary depending on manufacturing technique and corrosion allowance requirements.

4X7L RANGE

- Solid lugged type (through bolting arrangement)
- Retainerless design as standard (no leak path to atmosphere)
- Metal to metal seating for inherent fire safety
- Resilient seat option
- API 594 Design Standard
- ASME B16.34 Pressure/Temperature ratings
- PED 2014/68/EU (Cat III and Below)

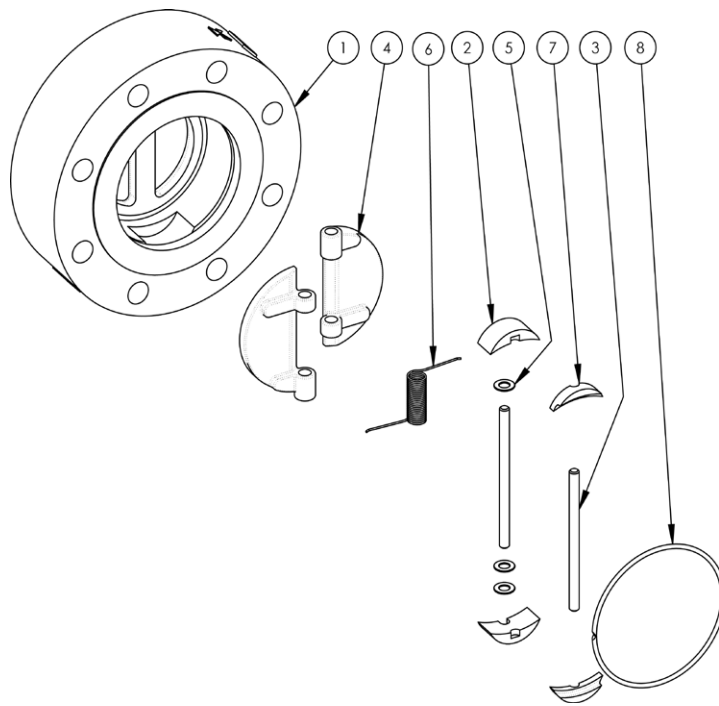

Item No.	Description	Qty
1	BODY	1
2	PIN CARRIER (BTM)	2
3	PIN	2
4	PLATE (DISC)	2
5	BEARING	-
6	TORSION SPRING	1
7	PIN CARRIER (TOP)	2
8	RETAINING CLIP	1

VIEW SHOWN IS GENERIC REPRESENTATION ONLY

4X7L PRINCIPAL DIMENSIONS

ASME B16.5

DN	NPS	ASME Rating	End Facing	ØA (mm)	B (mm)	ØC (mm)	Approx Mass (kg)
50	2"	150	RF	150	60	60	8
		300	RF	165	60	60	9
		600	RF/RTJ 23	165	60	60	9
		900	RF/RTJ 24	215	70	60	12
		1500	RF/RTJ 24	215	70	60	12
		2500	RF/RTJ 26	235	70	60	16
65	2.5"	150	RF	180	67	73	9
		300	RF	190	67	73	11
		600	RF/RTJ 26	190	67	73	11
		900	RF/RTJ 27	245	83	73	16
		1500	RF/RTJ 27	245	83	73	16
		2500	RF/RTJ 28	265	83	73	24
80	3"	150	RF	190	73	89	13
		300	RF	210	73	89	15
		600	RF/RTJ 31	210	73	89	15
		900	RF/RTJ 31	240	83	89	22
		1500	RF/RTJ 35	265	83	89	26
		2500	RF/RTJ 32	305	86	89	35
100	4"	150	RF	230	73	114	18
		300	RF	255	73	114	25
		600	RF/RTJ 37	275	79	114	30
		900	RF/RTJ 37	290	102	114	40
		1500	RF/RTJ 39	310	102	114	55
		2500	RF/RTJ 38	355	105	114	70

DN	NPS	ASME Rating	End Facing	ØA (mm)	B (mm)	ØC (mm)	Approx Mass (kg)
125	5"	150	RF	255	86	141	22
		300	RF	280	86	141	30
		600	RF/RTJ 41	330	TBC	141	TBC
		900	RF/RTJ 41	350	TBC	141	TBC
		1500	RF/RTJ 44	375	TBC	141	TBC
		2500	RF/RTJ 42	420	TBC	141	TBC
150	6"	150	RF	280	98	170	35
		300	RF	320	98	170	45
		600	RF/RTJ 45	355	136	170	77
		900	RF/RTJ 45	380	159	170	105
		1500	RF/RTJ 46	395	159	170	120
		2500	RF/RTJ 47	485	159	170	170
200	8"	150	RF	345	127	220	65
		300	RF	380	127	220	85
		600	RF/RTJ 49	420	165	220	130
		900	RF/RTJ 49	470	206	220	210
		1500	RF/RTJ 50	485	206	220	215
		2500	RF/RTJ 51	550	206	220	280
250	10"	150	RF	405	146	275	95
		300	RF	445	146	275	125
		600	RF/RTJ 53	510	213	275	235
		900	RF/RTJ 53	545	241	275	325
		1500	RF/RTJ 54	585	248	275	380
		2500	RF/RTJ 55	675	254	275	500

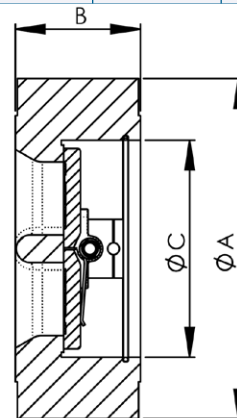
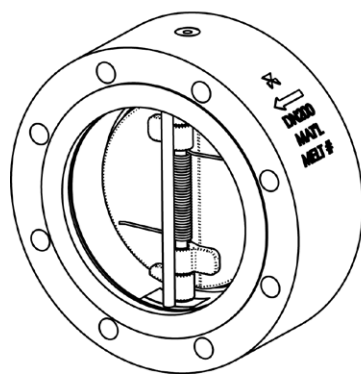

Notes:

Dimension's shown are nominal values only.

Weights may vary depending on manufacturing technique and corrosion allowance requirements.

4X7L PRINCIPAL DIMENSIONS

ASME B16.5

DN	NPS	ASME Rating	End Facing	ØA (mm)	B (mm)	ØC (mm)	Approx Mass (kg)
300	12"	150	RF	485	181	321	170
		300	RF	520	181	321	198
		600	RF/RTJ 57	560	229	326	294
		900	RF/RTJ 57	610	292	326	464
		1500	RF/RTJ 58	675	305	326	585
		2500	RF/RTJ 60	760	305	326	800?
350	14"	150	RF	535	184	360	200
		300	RF	585	222	360	315
		600	RF/RTJ 61	605	273	356	315
		900	RF/RTJ 62	640	356	356	775
		1500	RF/RTJ 63	750	356	356	910
		2500	-	-	-	-	-
400	16"	150	RF	595	191	406	285
		300	RF	650	232	406	490
		600	RF/RTJ 65	685	305	406	660
		900	RF/RTJ 66	705	384	390	800
		1500	RF/RTJ 67	825	384	390	1120
		2500	-	-	-	-	-

DN	NPS	ASME Rating	End Facing	ØA (mm)	B (mm)	ØC (mm)	Approx Mass (kg)
450	18"	150	RF	635	203	458	290
		300	RF	710	264	458	560
		600	RF/RTJ 69	745	362	458	1100
		900	RF/RTJ 70	785	451	458	1170
		1500	RF/RTJ 71	915	468	458	1670
		2500	-	-	-	-	-
500	20"	150	RF	700	219	508	350
		300	RF	775	292	508	700
		600	RF/RTJ 73	815	368	508	950
		900	RF/RTJ 74	855	451	500	1960
		1500	RF/RTJ 75	985	533	500	2250
		2500	-	-	-	-	-
600	24"	150	RF	815	222	610	400
		300	RF	915	318	610	1100
		600	RF/RTJ 77	940	438	610	1550
		900	RF/RTJ 78	1040	495	600	2350
		1500	RF/RTJ 79	1170	559	600	3250
		2500	-	-	-	-	-

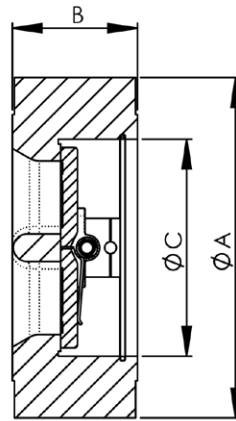
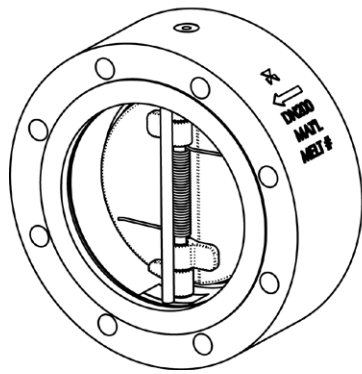

FOR ALTERNATIVE PRESSURE RATINGS, FLANGE STANDARDS AND LARGER SIZES CONSULT ABACUS VALVES INTERNATIONAL LTD.

Notes:

Dimension's shown are nominal values only.

Weights may vary depending on manufacturing technique and corrosion allowance requirements.

4X7U RANGE

- Double flanged type (independent bolting arrangement)
- Retainerless design as standard (no leak path to atmosphere)
- Metal to metal seating for inherent fire safety
- Resilient seat option
- API 594 Design Standard
- ASME B16.34 Pressure/Temperature ratings
- PED 2014/68/EU (Cat III and below)

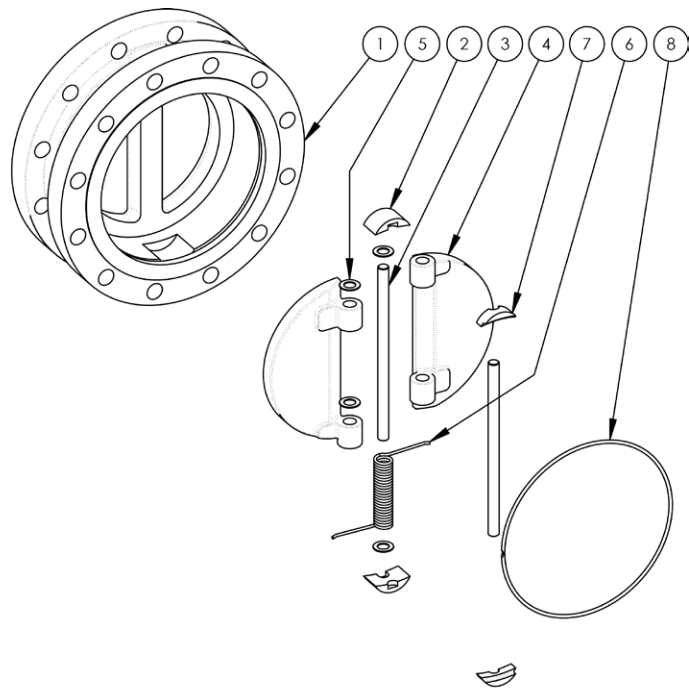

Item No.	Description	Qty
1	BODY	1
2	PIN CARRIER (BTM)	2
3	PIN	2
4	PLATE (DISC)	2
5	BEARING	-
6	TORSION SPRING	1
7	PIN CARRIER (TOP)	2
8	RETAINING CLIP	1

VIEW SHOWN IS GENERIC REPRESENTATION ONLY

4X7U PRINCIPAL DIMENSIONS

ASME B16.5

DN	NPS	ASME Rating	End Facing	ØA (mm)	B (mm)	ØC (mm)	Approx Mass (kg)
200	8"	150	RF	345	127	220	42
		300	-	-	-	-	-
		600	-	-	-	-	-
		900	-	-	-	-	-
250	10"	150	RF	405	146	275	86
		300	-	-	-	-	-
		600	RF/RTJ 53	510	213	275	185
		900	RF/RTJ 53	545	241	275	205
300	12"	150	RF	485	181	321	115
		300	RF	520	181	321	145
		600	RF/RTJ 57	560	229	326	225
		900	RF/RTJ 57	610	292	326	350
350	14"	150	RF	535	184	360	140
		300	RF	585	222	360	210
		600	RF/RTJ 61	605	273	360	315
		900	RF/RTJ 62	640	356	356	560

DN	NPS	ASME Rating	End Facing	ØA (mm)	B (mm)	ØC (mm)	Approx Mass (kg)
400	16"	150	RF	595	191	406	170
		300	RF	650	232	406	310
		600	RF/RTJ 65	685	305	406	430
		900	RF/RTJ 66	705	384	390	600
450	18"	150	RF	635	203	458	210
		300	RF	710	264	458	400
		600	RF/RTJ 69	745	362	458	605
		900	RF/RTJ 70	785	451	458	860
500	20"	150	RF	700	219	508	290
		300	RF	775	292	508	490
		600	RF/RTJ 73	815	368	508	760
		900	RF/RTJ 74	855	451	500	1055
600	24"	150	RF	815	222	610	380
		300	RF	915	318	610	690
		600	RF/RTJ 77	940	438	610	1250
		900	RF/RTJ 78	1040	495	600	1890

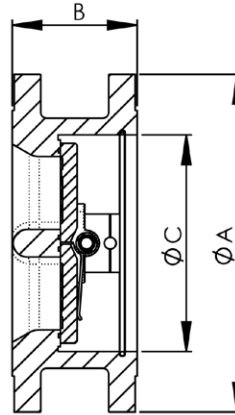
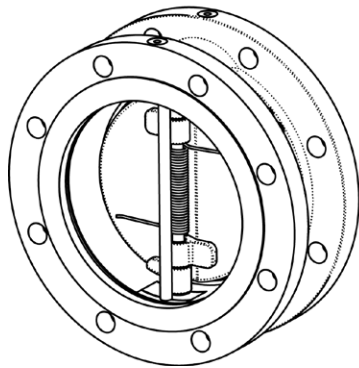

FOR ALTERNATIVE PRESSURE RATINGS, FLANGE STANDARDS AND LARGER SIZES CONSULT ABACUS VALVES INTERNATIONAL LTD.

Notes:

Dimension's shown are nominal values only.

Weights may vary depending on manufacturing technique and corrosion allowance requirements.

4X4 RANGE

- Double flanged, extended body type (Independent bolting arrangement)
- Retainerless design as standard (no leak path to atmosphere)
- Metal to metal seating for inherent fire safety
- Resilient seat option
- API 594 Compliant (except face to face)
- ASME B16.34 Pressure/Temperature ratings
- PED 2014/68/EU (Cat III and below)

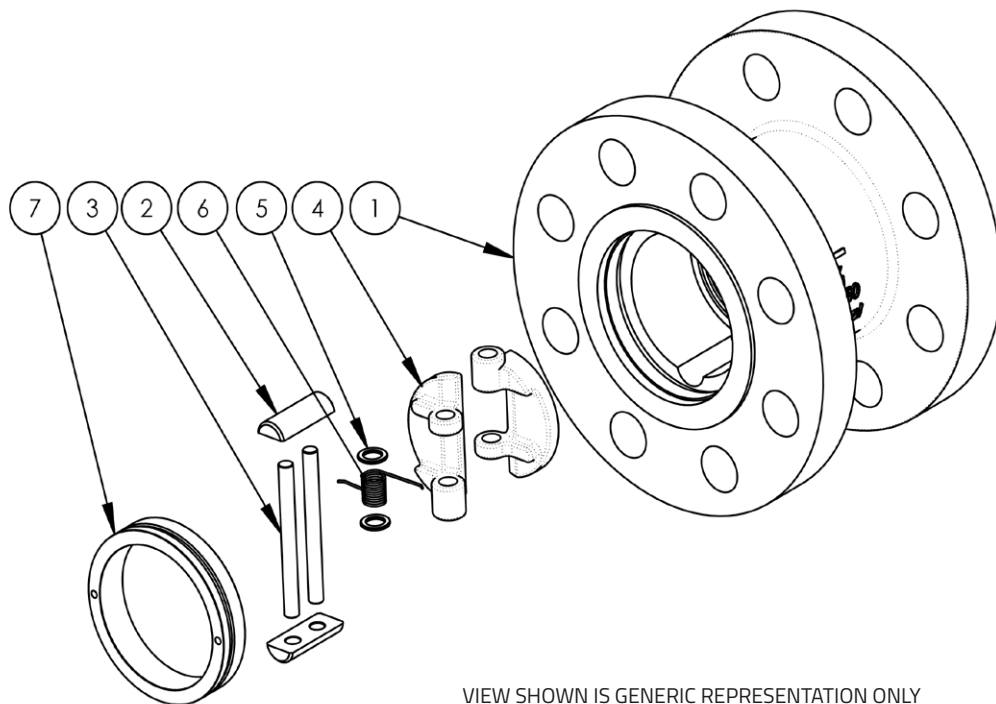

Item No.	Description	Qty
1	BODY	1
2	PIN CARRIER	2
3	PIN	2
4	PLATE DISC	2
5	BEARING	-
6	TORSION SPRING	1
7	FLANGE INSERT	1

4X4 PRINCIPAL DIMENSIONS

ASME B16.5

DN	NPS	ASME Rating	End Facing	ØA (mm)	B (mm)	ØC (mm)	Approx Mass (kg)
50	2"	150	RF	150	114	60	7
		300	RF	165	114	60	8
65	2.5"	150	RF	180	118	60	10
		300	RF	190	118	60	11
80	3"	150	RF	190	121	90	12
		300	RF	210	121	90	15
100	4"	150	RF	230	121	115	18
		300	RF	255	121	115	25
		600	RF	275	165	115	40
150	6"	150	RF	280	130	169	28
		300	RF	320	130	169	42
		600	RF	355	194	169	77
200	8"	300	RF	380	152	220	50
		600	RF	420	219	220	122
250	10"	300	RF	445	178	275	80

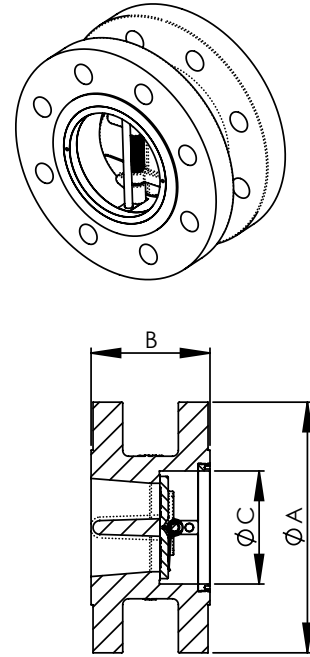

FOR ALTERNATIVE PRESSURE RATINGS, FLANGE STANDARDS, FACE TO FACE DIMENSIONS AND LARGER SIZES CONSULT ABACUS VALVES INTERNATIONAL LTD.

Notes:

Dimension's shown are nominal values only.

Weights may vary depending on manufacturing technique and corrosion allowance requirements.

4X7H RANGE

- Hub end connection type
- Retainerless design as standard (no leak path to atmosphere)
- Metal to metal seating for inherent fire safety
- Resilient seat option
- ASME B16.34 Pressure/Temperature ratings
- PED 2014/68/EU (Cat III and below)

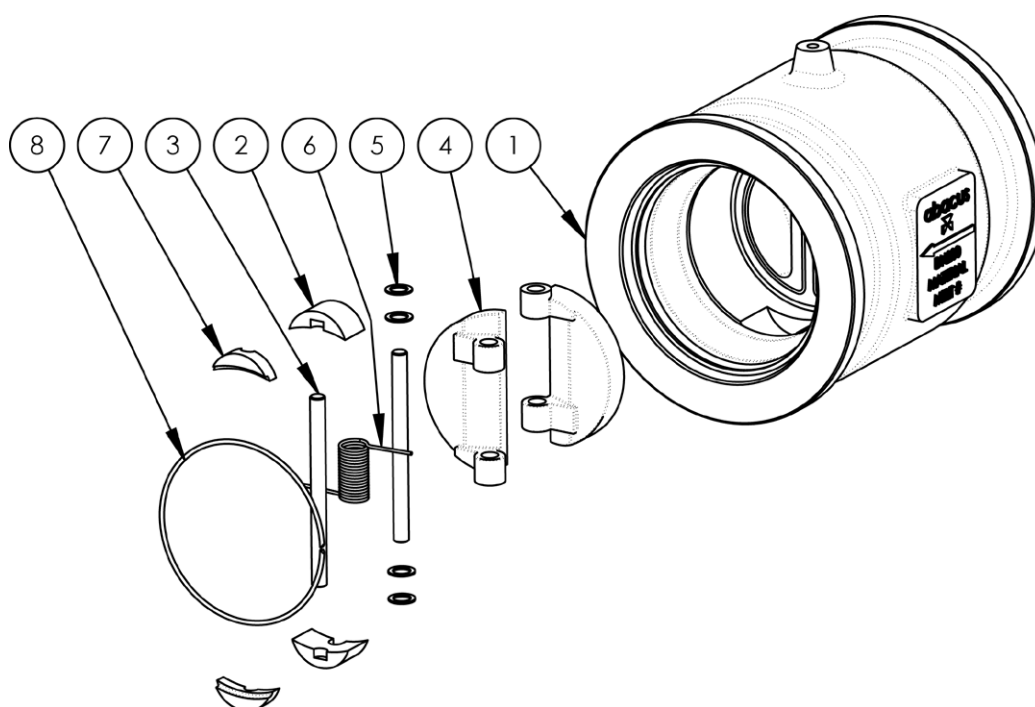

VIEW SHOWN IS GENERIC REPRESENTATION ONLY

Item No.	Description	Qty
1	BODY	1
2	PIN CARRIER (BTM)	2
3	PIN	2
4	PLATE (DISC)	2
5	BEARING	-
6	TORISON SPRING	1
7	PIN CARRIER (TOP)	2
8	RETAINING CLIP	1

Notes:

For specific principal dimensions contact Abacus Technical Department.

The 2" version is only available with retainer plugs.

Short and long pattern options available on common hub connector types.

Clamps, seals, mating hub ends and hardware are not supplied as standard with 4X7H range.

Purchaser must supply hub end details.

SPECIALS - 9X7 & 9X9 RANGE

- Compact twin plate range
- Can be configured to suit short or long pattern face to face
- Metal to metal seating for inherent fire safety
- Resilient seat option
- ASME B16.34 Pressure/Temperature ratings
- PED 2014/68/EU (PED Cat III and below)

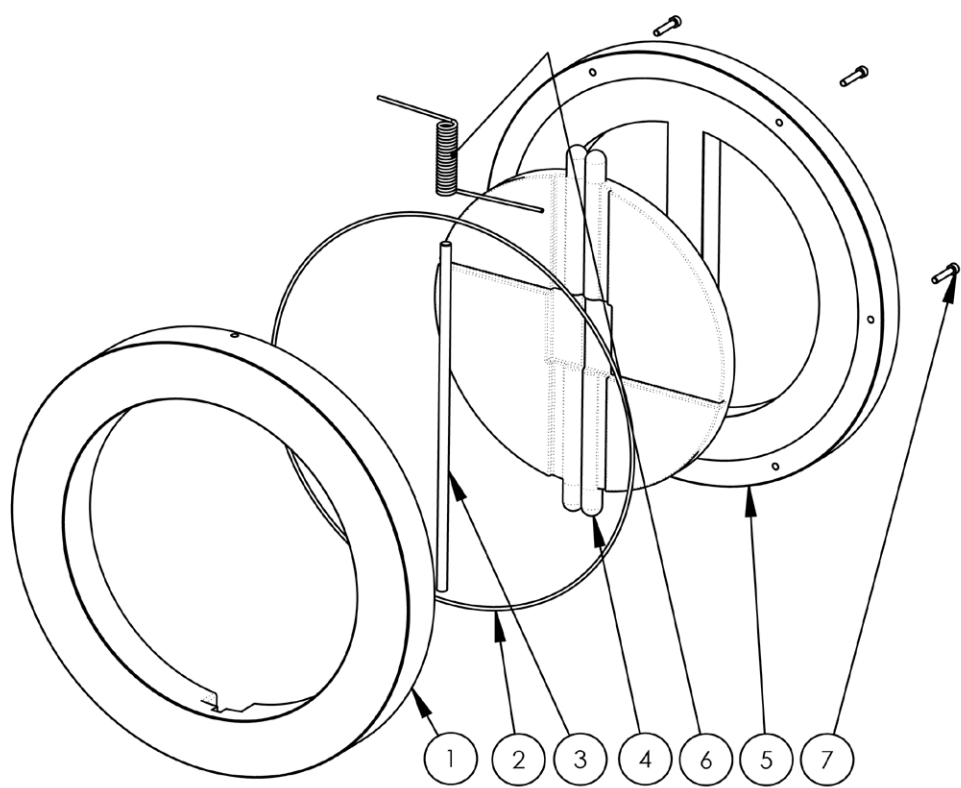

VIEW SHOWN IS GENERIC REPRESENTATION ONLY

Item No.	Description	Qty
1	BODY	1
2	O-RING	1
3	PIN	1
4	PLATE (DISC)	2
5	SEAT	1
6	TORSION SPRING	2
7	CAPSCREW	-

PRINCIPAL DIMENSIONS

9X7 Range (Short Pattern)							
DN	NPS	ASME Rating	End Facing	ØA (mm)	B (mm)	ØC (mm)	Approx Mass (kg)
50	2"	150	RF	105	17	60	2
65	2.5"	150	RF	124	20	73	3
80	3"	150	RF	137	24	89	4
100	4"	150	RF	175	27	114	5
125	5"	150	RF	197	32	141	7
150	6"	150	RF	222	32	170	8
200	8"	150	RF	279	45	220	20
250	10"	150	RF	339	47	275	35
300	12"	150	RF	409	58	326	55
350	14"	150	RF	451	77	333	60

9X9 Range (Long Pattern)							
DN	NPS	ASME Rating	End Facing	ØA (mm)	B (mm)	ØC (mm)	Approx Mass (kg)
50	2"	150	RF	105	60	60	5
65	2.5"	150	RF	124	67	73	10
80	3"	150	RF	137	73	89	12
100	4"	150	RF	175	73	114	14
125	5"	150	RF	197	86	141	21
150	6"	150	RF	222	98	170	24
200	8"	150	RF	279	127	220	55
250	10"	150	RF	339	146	275	100
300	12"	150	RF	409	181	326	125
350	14"	150	RF	451	-	333	-

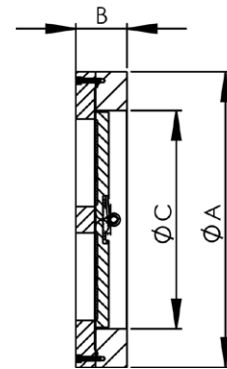
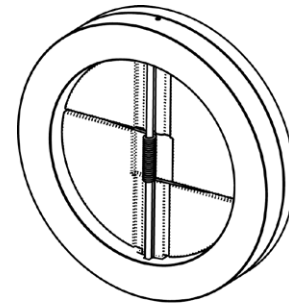

FOR ALTERNATIVE PRESSURE RATINGS, FLANGE STANDARDS AND LARGER SIZES CONSULT ABACUS VALVES INTERNATIONAL LTD.

A FULL RANGE OF COMPOSITE STRUCTURE CONFIGURATIONS AVAILABLE.

Notes:

Dimension's shown are nominal values only.

Weights may vary depending on manufacturing technique and corrosion allowance requirements.

STANDARD CONFIGURATIONS

417XM	
Part	Material
Body	ASTM B148 C95800
Pin Carriers	ASTM A494 M35-1
Hinge & Stop Pins	UNS N04400
Disc Plates	ASTM B148 C95800
Spring	UNS N07750
Bearings	UNS N04400
Retaining Clip	UNS N07750

427XM	
Part	Material
Body	ASTM A216 WCB / ASTM A105
Pin Carriers	ASTM A351 CF8M
Hinge & Stop Pins	ASTM A182 F316
Disc Plates	ASTM A351 CF8M
Spring	UNS N07750
Bearings	AISI 316
Retaining Clip	AISI 316

437XM	
Part	Material
Body	ASTM A352 LCC
Pin Carriers	ASTM A351 CF8M
Hinge & Stop Pins	ASTM A182 F316
Disc Plates	ASTM A351 CF8M
Spring	UNS N07750
Bearings	AISI 316
Retaining Clip	AISI 316

447XM	
Part	Material
Body	ASTM A351 CF8M / ASTM A182 F316
Pin Carriers	ASTM A351 CF8M
Hinge & Stop Pins	ASTM A182 F316
Disc Plates	ASTM A351 CF8M
Spring	UNS N07750
Bearings	AISI 316
Retaining Clip	AISI 316

487XM	
Part	Material
Body	ASTM A995 Gr4A / ASTM A182 F51
Pin Carriers	ASTM A995 Gr4A
Hinge & Stop Pins	ASTM A182 F51
Disc Plates	ASTM A995 Gr4A
Spring	UNS N07750
Bearings	ASTM A182 F51
Retaining Clip	UNS N07750

4117XM	
Part	Material
Body	ASTM A995 Gr6A / ASTM A182 F55
Pin Carriers	ASTM A995Gr6A
Hinge & Stop Pins	ASTM A182 F55
Disc Plates	ASTM A995 Gr6A
Spring	UNS N07750
Bearings	ASTM A182 F55
Retaining Clip	UNS N07750

4247XE	
Part	Material
Body	EN-GJS-500-7 / EPDM Integral Seat
Pin Carriers	ASTM A351 CF8M
Hinge & Stop Pins	ASTM A182 F316
Disc Plates	ASTM A351 CF8M
Spring	UNS N07750
Bearings	AISI 316
Retaining Clip	AISI 316

4147IM	
Part	Material
Body	ASTM A494 CW6MC
Pin Carriers	ASTM A494 CW6MC
Hinge & Stop Pins	UNS N06625
Disc Plates	ASTM A494 CW6MC
Spring	UNS N06625
Bearings	UNS N06625
Retaining Clip	UNS N06625

The above is a snap shot of common standard configurations for the Abacus 4X7 range of twin plates.

Refer to the part number configurator for alternative options or contact Abacus for specific requirements.

Full range of API trims available.

Specialised linings and coatings available.

Integral and renewable resilient seating options available.

TWIN PLATE PRESSURE DROP CHART

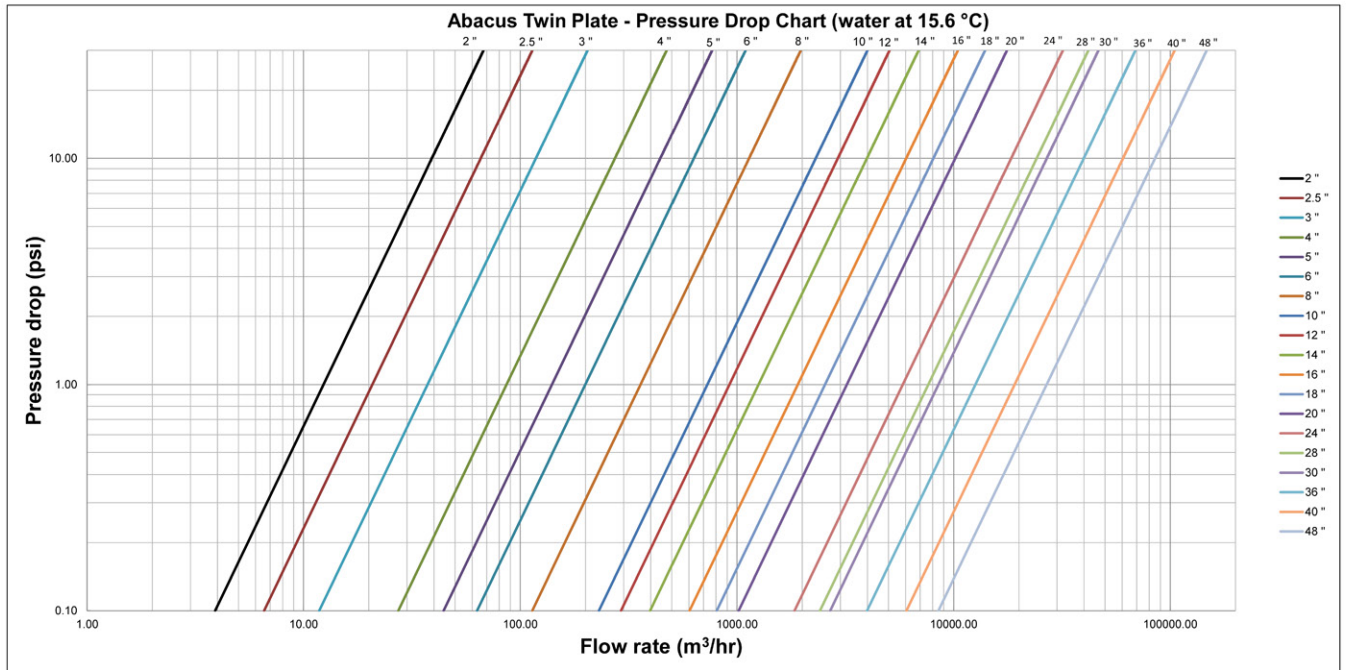

FLOW COEFFICIENT (Cv) and FLOW FACTOR (Kv)			
NPS	DN	KV	CV
2	50	47	55
2½	65	79	93
3	80	142	166
4	100	329	385
5	125	533	624
6	150	760	890
8	200	1367	1600
10	250	2776	3250
12	300	3511	4110
14	350	4783	5600
16	400	7260	8500
18	450	9695	10610
20	500	12232	14320
24	600	22166	25950
28	700	29067	34030
30	750	32373	37900
36	900	47961	56150
40	1000	72775	85200
48	1200	102286	119750

CRITICAL VELOCITY

For a horizontally orientated twin plate valve fitted with standard Abacus torsion springs:

Critical mean inlet velocity = 3m/s (water)

For fluids other than water at standard conditions, the following formula can be used to best approximate the equivalent water velocity:

$$v_{water_equiv} = v_{fluid} \sqrt{\frac{\rho_{fluid}}{\rho_{water}}}$$

Abacus recommends that twin plate check valves are sized to be operated in the fully open position to ensure maximum service life and performance.

For valves which are installed for inclined or vertical up-flow, then gravity effects must be considered when evaluating the mean inlet velocity required to fully open the valve in addition to the dynamic force required to overcome the spring force.

Incorrectly sized valves can experience disc flutter and seat chatter.

Kv: The flow of water through a valve at 15.6°C in cubic metres per hour (m³/hr) with a pressure drop of 1 bar.
 Cv: The flow of water through a valve at 60°F in US gallons/minute (USgpm) with a pressure drop of 1 psi.

OTHER PRODUCTS



3X7 Range
Integral Flanged Connection
API 6D Face to Face
Sizes 2"-42"
Rating ASME Class 150 - 2500



SP3X7 Range
Integral Flanged Connection
Manufacturer's Short Pattern Face to Face
Sizes 2"-42"
Rating ASME Class 150 - 2500



3X7H Range
Hub End Connection
Manufacturer's Pattern Face to Face
Sizes 2"-42"
Rating ASME Class 150 - 2500



3X5 Range
Wafer Connection
Manufacturer's Short Pattern Face to Face
Sizes 2"-42"
Rating ASME Class 150 - 2500

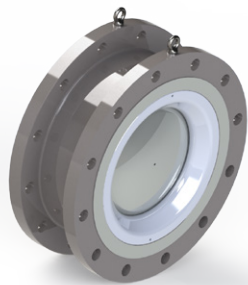

3X5U Range
Double Flanged Wafer Connection
Manufacturer's Short Pattern Face to Face
Sizes 2"-42"
Rating ASME Class 150 - 2500

axial non-slam nozzle check valves

Alternative pressure ratings, sizes and end connections available upon request

Abacus product is 2014/68/EU approved for PED Cat III and below

sales@abacusvalves.com

www.abacusvalves.com

CERTIFICATION & APPROVALS



Current issue date: 30 March 2023
 Expiry date: 31 June 2023
 Certificate identity number: 10797629

Original approval(s):
 ISO 9001:12 June 2015
 ISO 45001:26 November 2021
 ISO 14001:18 September 2020

Certificate of Approval

This is to certify that the Management System of:
Abacus Valves International Ltd

Paddockholm Industrial Estate, Unit 4, Riverside Road, Kibrimie, KA25 7EW, United Kingdom

has been approved by LRQA to the following standards:
ISO 9001:2015, ISO 45001:2018, ISO 14001:2015

Approval number(s): ISO 9001 – 0005276, ISO 45001 – 00017590, ISO 14001 – 00050389

The scope of this approval is applicable to:
 Design, manufacture and supply of check valves.

David Derrick
 Regional Director, UKAM
 Issued by: LRQA Limited



LRQA Group Limited, its affiliates and subsidiaries and their respective officers, employees or agents are, individually and collectively, referred to in this clause as 'LRQA'. LRQA assumes no responsibility and shall not be liable to any person for any loss, damage or expense caused by reliance on the information or advice in this document or for any other reason, unless that person has agreed to the provision of this information or advice and in that case any responsibility or liability is acknowledged in the terms and conditions issued by LRQA Limited, 1 Trinity Park, Bournemouth, Dorset, BH1 1TA, United Kingdom.

Page 1 of 1



Current issue date: 24 February 2023
 Expiry date: 23 February 2025
 Certificate identity number: 10674619

Original approval(s):
 ISO 29001:24 February 2023

Certificate of Approval

This is to certify that the Management System of:
Abacus Valves International Ltd

Paddockholm Industrial Estate, Block 4, Riverside Road, Kibrimie, KA25 7EW, United Kingdom

has been approved by LRQA to the following standards:
ISO 29001:2020

Approval number(s): ISO 29001 – 00048158

The scope of this approval is applicable to:
 Design and manufacture & supply of check valves.

David Derrick
 Regional Director, UKAM
 Issued by: LRQA Limited



LRQA Group Limited, its affiliates and subsidiaries and their respective officers, employees or agents are, individually and collectively, referred to in this clause as 'LRQA'. LRQA assumes no responsibility and shall not be liable to any person for any loss, damage or expense caused by reliance on the information or advice in this document or for any other reason, unless that person has agreed to the provision of this information or advice and in that case any responsibility or liability is acknowledged in the terms and conditions issued by LRQA Limited, 1 Trinity Park, Bournemouth Lane, Bournemouth BH7 7EJ, United Kingdom.

Page 1 of 1



EU CERTIFICATE OF CONFORMITY

In accordance with the requirements of the Pressure Equipment Directive 2014/68/EU.

This is to certify that the Quality Management System of:
Abacus Valves International Limited
 Kibrimie
 Ayrshire
 United Kingdom

has been assessed against the requirements of Annex III, Module H of the above Directive and conforms to the requirements for the products shown below:

Design and Manufacture of Axial Disc, Nozzle, Twin Plate and Wafer Single Plate Check Valves

Approval is subject to the continued maintenance of the quality system in accordance with the requirements of the above Directive for the product(s) listed on the attached schedule.

Authorisation is hereby given to use the Notified Body Identification Number in accordance with the requirements of the specified Directive in relation to the products as identified above.



Certificate No.: 0343/PED/BHM/PRJ11100425680/1
 Original Approval: 03 May 2024
 Current Issue: 03 May 2024
 Certificate Expiry: 02 May 2027
 Notified Body No. 0343

Prafulla Vyas on behalf of LRQA Nederland B.V.

LRQA Nederland B.V. (Reg. no. 2407968) is a private limited company registered in the Netherlands with registered office at Borge 47, 3588 AJ Breda, - a subsidiary of LRQA Group Limited.

LRQA Group Limited, its affiliates and subsidiaries and their respective officers, employees or agents are, individually and collectively, referred to in this clause as 'LRQA'. LRQA assumes no responsibility and shall not be liable to any person for any loss, damage or expense caused by reliance on the information or advice in this document or for any other reason, unless that person has agreed to the provision of this information or advice and in that case any responsibility or liability is acknowledged in the terms and conditions issued by LRQA Limited, 1 Trinity Park, Bournemouth, Dorset, BH1 1TA, United Kingdom.

Page 1 of 2

CERTIFICATE SCHEDULE

0343/PED/BHM/PRJ11100425680/1

In accordance with the requirements of the Pressure Equipment Directive 2014/68/EU

Product(s)	Size Range	Rating	Design Code
Axial Disc and Nozzle Check Valves	>1" to 42"	Class 125 to 2500	ASME B16.34: 2013 API 594 7th Edition
	>DN25 to DN1050	PN6 to PN420	BS EN 12516: 2014 ASME B16.34: 2013
Twin Plate Check Valves	2" to 72"	Class 125 to 4500	ASME B16.34: 2013 API 594 7th Edition
	DN050 to DN1800	PN6 to PN750	BS EN 12516: 2014
Wafer Single Plate Check Valves	>1" to 36"	Class 125 to 2500	ASME B16.34: 2013
	DN015 to DN900	PN6 to PN420	BS EN 12516: 2014

Materials as stated in Design Appraisal Documents: -

COV1332429 O-28971/CA
 COV1312429 O-28972/CA
 COV1512151 O-30766/CA
 COV1512151 O-30809/CA
 COV1512151 O-30811/CA
 COV1512151 O-30812/CA
 COV1716235 O-33385/AT
 COV1716235 O-33386/AT

Schedule Issue: 00
 Date of Schedule Issue: 03 May 2024
 Notified Body No. 0343

Prafulla Vyas on behalf of LRQA Nederland B.V.

LRQA Nederland B.V. (Reg. no. 2407968) is a private limited company registered in the Netherlands with registered office at Borge 47, 3588 AJ Breda, - a subsidiary of LRQA Group Limited.

LRQA Group Limited, its affiliates and subsidiaries and their respective officers, employees or agents are, individually and collectively, referred to in this clause as 'LRQA'. LRQA assumes no responsibility and shall not be liable to any person for any loss, damage or expense caused by reliance on the information or advice in this document or for any other reason, unless that person has agreed to the provision of this information or advice and in that case any responsibility or liability is acknowledged in the terms and conditions issued by LRQA Limited, 1 Trinity Park, Bournemouth, Dorset, BH1 1TA, United Kingdom.

Page 1 of 2



VALVE DATA SHEET - QUESTIONNAIRE

		DATA SHEETS - TWIN PLATE CHECK VALVES	
		Rev. 00	Page: 1 of 1
TWIN PLATE CHECK VALVE QUESTIONNAIRE			
Piping Class:	Ped Category:		Corrosion Allowance:
TAG NO.	LINE NO.	P&ID NO.	
	DESCRIPTION	MATERIALS	Notes
TYPE / ORIENTATION			
SIZE			
LOCATION			
DESIGN STANDARD			
RATING			
NACE REQUIREMENT			
END CONNECTION			
FACE TO FACE DIMENSIONS			
SERVICE FLUID		CORROSIVE SERVICE :	
FLUID PHASE			
COMPRESSIBILITY FACTOR			
MOLECULAR WEIGHT (kg/kmol)			
FLOW RATE (m ³ /hr)	Minimum		
	Normal		
	Maximum		
SYSTEM DECELERATION (m/s ²)			
FLUID DENSITY (kg/m ³)			
FLUID VELOCITY (m/s)			
VISCOSITY (cP)			
MAX ALLOWABLE PRESSURE DROP (Pa)			
SERVICE CONDITIONS	Operating	Design	
a) PRESSURE (MPa)			
b) TEMPERATURE (°C)			
BODY			
BODY SEAT			
PLATES			
PLATES SEAT			
SPRING			
WETTED PARTS			
TESTING			
MARKING			
NDE REQUIREMENTS			
CERTIFICATION			
COATING			

Notes:

ADVANTAGES

- Spring assisted, dynamic response (non-slam closure)
- Optimum strength to weight ratio
- Significant cost saving on valve purchase and installation costs
- Easily installed between all common flanges
- Readily configured for a wide range of material combinations
- Inherently fire safe with no leak paths to atmosphere
- Resilient seating options
- Tight shut off
- Can be installed in various orientations
- Industry recognised check valve option
- Suitable for a wide range of fluids and applications
- Low maintenance costs
- API594, API6D, API6A and customer specific design available
- Suitable for manufacture from castings and forgings
- Short lead time

NOTES



ABACUS VALVES INTERNATIONAL LTD

Abacus Valves International Ltd

Block 4, Riverside Road
Paddockholm Industrial Estate
Kilbirnie KA25 7EW

t: **+44 (0) 1505 681 777**
f: **+44 (0) 1505 683 999**
e: **sales@abacusvalves.com**
w: **www.abacusvalves.com**

