

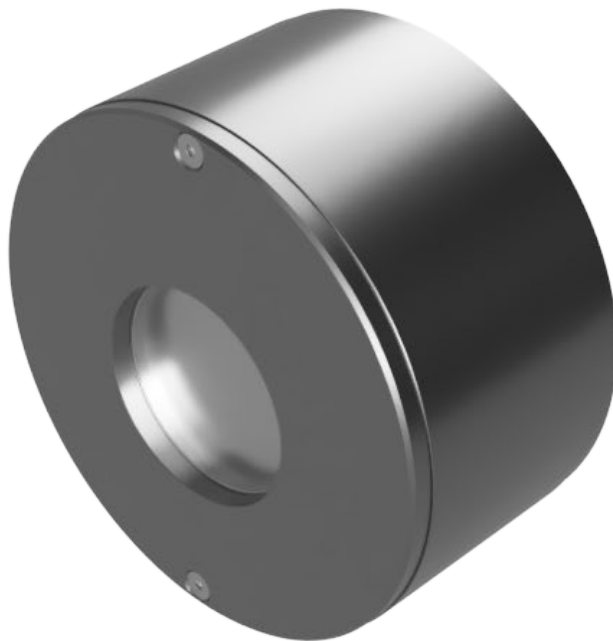

ABACUS
Valves International

SPRUNG SWING TYPE CHECK VALVE

Installation, Operation & Maintenance Manual



www.abacusvalves.com

TABLE OF CONTENTS

Introduction	3
Copyright	3
Health and Safety at Work	3
Storage/Handling	4
Installation	4
Operation	5
Maintenance	5
Supplementary Safety Information	5
Intended Use	5
Contacts	9

INTRODUCTION

This generic manual is written for operating, maintenance and supervisory personnel. The manual must be read, understood and observed by operating personnel.

Scope of valves covered -: *SPRUNG SWING TYPE* ranges.

COPYRIGHT

The copyright for this manual remains with Abacus Valves International Ltd. The instructions, images and drawings contained herein may not be reproduced either in full or in part, nor used for competitive purposes or communicated to other parties without authorization from Abacus Valves International Ltd.

HEALTH AND SAFETY AT WORK

Please ensure that all relevant Health and Safety issues and regulations are strictly adhered to, prior to and during any installation work carried out on these Abacus Nozzle Check Valves.

It is essential that whenever work is being undertaken on a valve that may involve the release of internal pressure, that the valve is fully depressurised prior to any such like work, with the line drained and isolated safely.

It is essential that when handling the valve assembly that the user is aware of the mass of the components. It is the users responsibility to ensure that safe working practices are followed at all times.

This manual had been designed to assist and act as a guideline for users but is not a replacement for adequately trained, competent staff. It is the responsibility of the end user to ensure that only qualified staff undertake relevant duties.

Abacus Valves International Ltd cannot be held responsible for any accidents arising from incorrect installation, operation or maintenance. The responsibility must rest wholly with the end user.

IMPORTANT NOTE:

IF IN DOUBT ABOUT ANY OF THE FOLLOWING CONTENT, CONTACT ABACUS VALVES INTERNATIONAL LTD AND REQUEST THE TECHNICAL DEPARTMENT.



STORAGE / HANDLING

- Valves should be stored in a clean and dry environment and within the temperature limitations of the valve. Protection is recommended.
- They should not be crushed or used to support other items.
- When handling the valves, the preferred method is to lift the valve using the lifting points provided.

INSTALLATION

- Ensure that the valve is clean and free from any packing material or preservative and that it is working correctly and that the disc will not foul anything downstream when the valve is fully open.
- Check Valves can be installed in the horizontal plane (with the hinges normally at the top) or the vertical plane (with upward flow), by noting the flow arrow, centring the valve between parallel flanges and full faced gaskets, inserting bolts or studs and tightening nuts evenly to the correct torque, following the gasket manufacturer's recommendations. Valve must be fully supported across its end faces.
- Check valves should ideally be placed at a minimum distance of ten times the diameter of the pipe downstream from pumps or features in the pipeline liable to induce turbulence. Failure to observe this recommendation could adversely affect valve performance and service lifetime.

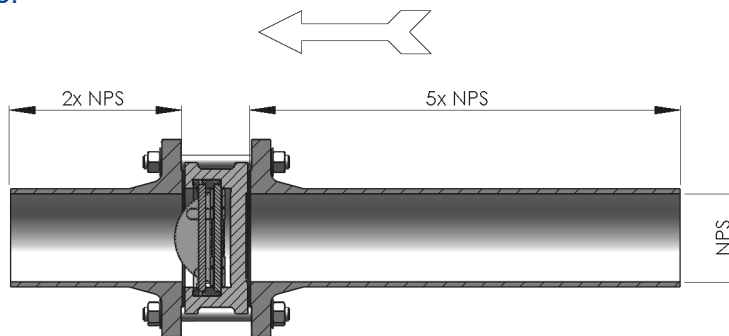

- Please consult Abacus if vertical downflow is desired. This may require technical evaluation.
- Twin plate check valves are not piggable.



OPERATION

Valves work on a pressure differential and must be operated within their pressure and temperature limitations.

MAINTENANCE

Remove valve from pipeline by loosening all flange nuts and removing sufficient bolts or studs to allow the valve to be withdrawn from between the flanges.

Clean the valve to remove any aggressive materials.

Dismantle the valve by removing the retaining pins, this allows removal of the seat, disc, spring, pin and seal.

Clean all parts with a suitable solvent.

Replace any worn or damaged items.

Lap in metal seats or fit new resilient seat and seal as necessary.

Assemble the valve by fitting the disc, spring, retainer and pins.

Finally replace the valve in the pipeline by following the installation instructions above. .

Supplementary Safety Information

Maintenance Instructions

Safe operation of these products can only be guaranteed if they are properly installed, commissioned, used and maintained by qualified personnel (see Section 11 of this document) in compliance with the operating instructions. General installation and safety instructions for pipeline and plant construction, as well as the proper use of tools and safety equipment must also be complied with.

1. Intended use

Referring to the Installation and Maintenance Instructions, name-plate and Technical Information Sheet, check that the product is suitable for the intended se/application. The products listed below comply with the requirements of the European Pressure Equipment Directive 2014/68/EU and PESR and carry the mark when so required. The products fall within the following Pressure Equipment Directive categories:

Products		Group 1 Gases	Group 2 Gases	Group1 Liquids	Group 2 Liquids
ANSI	DN50-100	2	1	2	SEP
	DN150-200	3	2	2	SEP
	DN250-300	3	2	2	1
Products		Group 1 Gases	Group 2 Gases	Group1 Liquids	Group 2 Liquids
DIN	DN50	2	1	SEP	SEP
	DN80-100	2	1	2	SEP
	DN150-200	3	2	2	SEP
	DN250-300	3	2	2	1



i) Abacus Valves International Ltd should be contacted to confirm the suitability of the product for the application being considered.

ii) Check material suitability, pressure and temperature and their maximum and minimum values. If the maximum operating limits of the product are lower than those of the system in which it is being fitted, or if malfunction of the product could result in a dangerous over pressure or over temperature occurrence, ensure a safety device is included in the system to prevent such over-limit situations.

iii) Determine the correct installation situation and direction of fluid flow.

iv) Abacus Valves International Ltd products are not intended to withstand external stresses that may be induced by any system to which they are fitted. It is the responsibility of the installer to consider these stresses and take adequate precautions to minimize them.

v) Remove protection covers from all connections before installation.

2. Access

Ensure safe access and if necessary, a safe working platform (suitably guarded) before attempting to work on the product. Arrange suitable lifting gear if required.

3. Lighting

Ensure adequate lighting, particularly where detailed or intricate work is required.

4. Hazardous liquids or gases in the pipeline

Consider what is in the pipeline or what may have been in the pipeline at some previous time. Consider: flammable materials, substances hazardous to health, extremes of temperature.

5. Hazardous environment around the product

Consider: explosion risk areas, lack of oxygen (e.g., tanks, pits), dangerous gases, extremes of temperature, hot surfaces, fire hazard (e.g., during welding), excessive noise, moving machinery.

6. The system

Consider the effect on the complete system of the work proposed. Will any proposed action (e.g., closing isolation valves, electrical isolation) put any other part of the system or any personnel at risk?

Dangers might include isolation of vents or protective devices or the rendering ineffective of controls or alarms. Ensure isolation valves are turned on and off in a gradual way to avoid system shocks.



7. Pressure systems

Ensure that any pressure is isolated and safely vented to atmospheric pressure. Consider double isolation (double block and bleed) and the locking or labelling of closed valves. Do not assume that the system has depressurized even when the pressure gauge indicates zero.

8. Temperature

Allow time for temperature to normalize after isolation to avoid danger of burns. Valves fitted with PTFE seats must not be subjected to temperatures above 260°C (500°F) and valves with Viton seats 315°C (599°F). Above these temperatures toxic fumes may be given off. Avoid inhalation of fumes or skin contact.

9. Tools and consumables

Before starting work ensure that you have suitable tools and/or consumables available. Use only genuine Abacus Valves replacement parts.

10. Protective clothing

Consider whether you and/or others in the vicinity require any protective clothing to protect against the hazards of, for example, chemicals, high/low temperature, radiation, noise, falling objects, and dangers to eyes and face.

11. Permits to work

All work must be carried out or be supervised by a suitably competent person. Installation and operating personnel should be trained in the correct use of the product according to the Installation and Maintenance Instructions. Where a formal 'permit to work' system is in force it must be complied with. Where there is no such system, it is recommended that a responsible person should know what work is going on and, where necessary.

12. Handling

Manual handling of large and/ or heavy products may present a risk of injury. Lifting, pushing, pulling, carrying or supporting a load by bodily force can cause injury particularly to the back. You are advised to assess the risks taking into account the task, the individual, the load and the working environment and use the appropriate handling method depending on the circumstances of the work being done.

13. Residual hazards

In normal use the external surface of the product may be very hot. If used at the maximum permitted operating conditions the surface temperature of some products may reach temperatures in excess of 300°C (572°F). Many products are not self-draining. Take due care when dismantling or removing the product from an installation (refer to 'Maintenance instructions').

14. Freezing

Provision must be made to protect products which are not self-draining against frost damage in environments where they may be exposed to temperatures below freezing point.

15. Safety information - Product specific

See the relevant Section in the attached Installation and Maintenance Instructions for specific details relating to this product.



16. Disposal

Unless otherwise stated in the Installation and Maintenance Instructions, this product is recyclable, and no ecological hazard is anticipated with its disposal providing due care is taken. However, if the valve is fitted with a Viton or PTFE seat, special care must be taken to avoid potential health hazards associated with decomposition/burning of these seats.

Viton:

- Can be landfilled, when in compliance with National and Local regulations
- Can be incinerated, but a scrubber must be used to remove Hydrogen Fluoride, which is evolved from the product and with compliance to National and Local regulations.
- Is insoluble in aquatic media.

PTFE:

- Can only be disposed of by approved methods, not incineration.
- Keep PTFE waste in a separate container, do not mix it with other rubbish, and consign it to a landfill site.

17. Returning products

Customers and stockists are reminded that under EC Health, Safety and Environment Law, when returning products to Abacus Valves International Ltd, they must provide information on any hazards and the precautions to be taken due to contamination residues or mechanical damage which may present a health, safety or environmental risk. This information must be provided in writing including Health and Safety data sheets relating to any substances identified as hazardous or potentially hazardous.



Abacus Contacts:



**Abacus Valves International Ltd
Block 4
Riverside Road
Paddockholm Industrial Estate
Kilbirnie
KA25 7EW**

T. +44 (0) 1505 681 777

**E. sales@abacusvalves.com (Sales)
documentation@abacusvalves.com (Quality Department)
admin@abacusvalves.com (Expediting)**

W. www.abacusvalves.com

